

TOX®-Clinching Technology

Clinching Tools and Accessories

Data sheet 80.07
2021 / 07

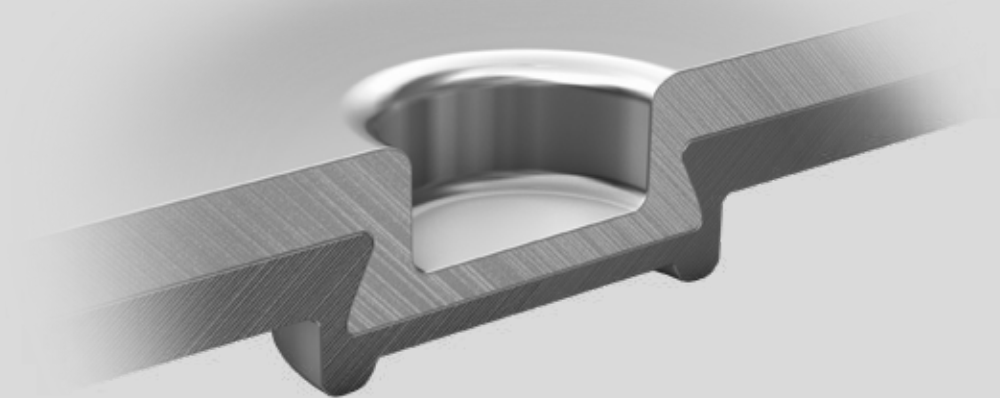

Tools

Flanged Tools

The dimensions and shapes of TOX®-Clinching Tools are standardized. Besides the standard tool lengths and point diameters listed here, many special solutions are available on request.

Thus, the punches and dies can be adapted to the geometry of the used piece parts. For detailed information please contact our local sales representations.

TOX®-Flanged Punch

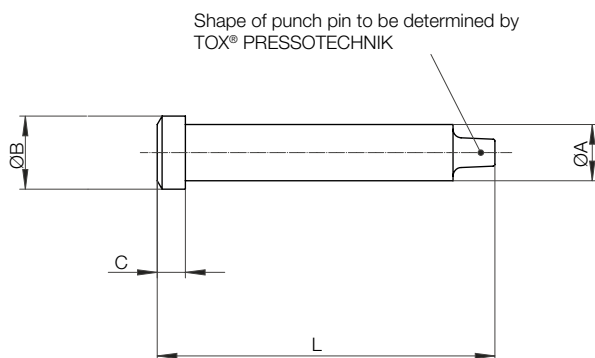

Type	L	Ø A ^{-0.005} / _{-0.020}	Ø B	C	Point Ø
TOX 03.140	40	3	5	3	2
TOX 10.25	60	10	13	5	3 - 12
TOX 10.180	80	10	13	5	3 - 12
TOX 10.200	100	10	13	5	3 - 12
TOX 10.220	120	10	13	5	3 - 12
TOX 14.25	60	14	17	5	6 - 12

Dimensions in mm

TOX®-Round Joint flanged die

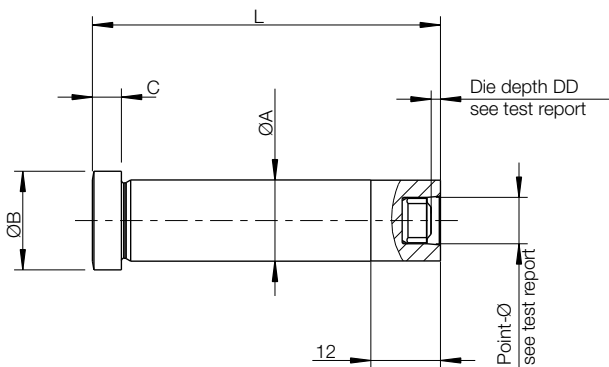

Type	L	Ø A ^{-0.005} / _{-0.020}	Ø B	C	Point Ø
TOX 04.130	30	4	6	3	2
TOX 10.25	60	10	13	5	3 / 4 / 5 / (6)*
TOX 10.180	80	10	13	5	3 / 4 / 5 / (6)*
TOX 10.200	100	10	13	5	3 / 4 / 5 / (6)*
TOX 12.25	60	12	15	5	6
TOX 14.25	60	14	17	5	8
TOX 14.180	80	14	17	5	8
TOX 14.200	100	14	17	5	8
TOX 16.25	60	16	19	5	10
TOX 20.25	60	20	23	5	12

* only after consulting TOX® PRESSOTECHNIK

Dimensions in mm

Special shapes of flanged tools

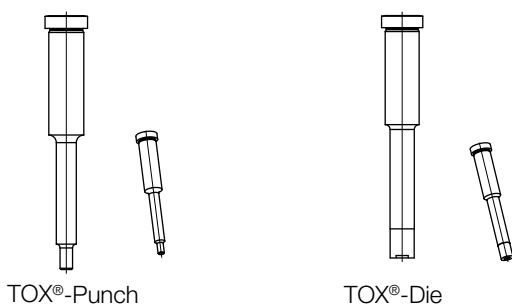

Tapers

For piece parts with small flange widths or for components which require a penetration of the tool, flanged tools with tapered flange can be used.

Please note that, due to the press forces, the design is limited. Each tool with special shape has to be analyzed in the test laboratory.

Flanged Tools

TOX®-SKB flanged die

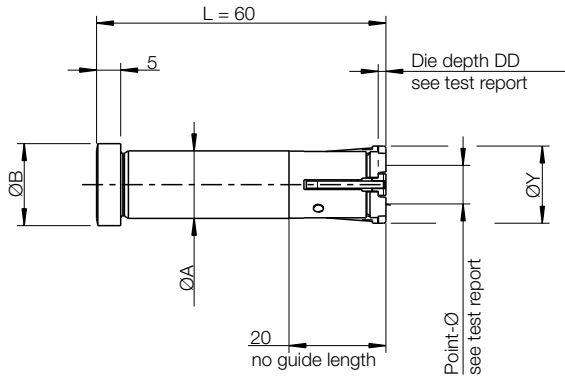

Type	L	Ø A ^{-0.005 -0.020}	Ø B	Point Ø	Y**
SKB 10.25	60	10	13	5 - 6	12
SKB 12.25	60	12	15	6 - 7	14
SKB 14.25	60	14	17	8 - 9	16
SKB 14.180	80	14	17	8 - 9	16
SKB 14.200	100	14	17	8 - 9	16
SKB 14.220	120	14	17	8 - 9	16
SKB 16.25*	60	16	19	8 - 10	17.5

* Joining with intermediate layer (e.g. glue/textiles) Dimensions in mm
 ** = with max. opened die

TOX®-TWINpoint flanged punch

Type TOX 210, 214, 218

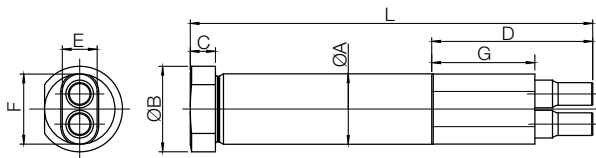

Type	L	Ø A ^{-0.005 -0.020}	Ø B	C	D	E	F	G	Point Ø
TOX 210.180	80	10	13	5	28	6	10	14.5	4
TOX 210.200	100	10	13	5	28	6	10	14.5	4
TOX 210.220	120	10	13	5	28	6	10	14.5	4
TOX 214.180	80	14	17	5	28	7	12	14.5	5
TOX 214.180	80	14	17	5	32	8	14	20.5	6
TOX 214.200	100	14	17	5	28	7	12	14.5	5
TOX 214.200	100	14	17	5	32	8	14	20.5	6
TOX 214.220	120	14	17	5	28	7	12	14.5	5
TOX 214.220	120	14	17	5	32	8	14	20.5	6
TOX 218.200	100	18	21	5	32	10	18	20.5	8
TOX 218.220	120	18	21	5	32	10	18	20.5	8

Dimensions in mm

Type 2 x TOX

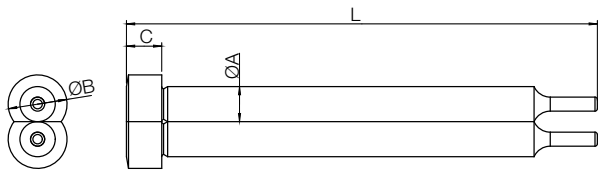

Type	L	Ø A ^{-0.005 -0.020}	Ø B	C	D	E	F	G	Point Ø
2 x TOX 03.141	40	3	5	3	-	-	-	-	3
2 x TOX 10.205	100	10	13	5	-	-	-	-	10
2 x TOX 10.227	120	10	13	5	-	-	-	-	10

Dimensions in mm

TOX®-TWINpoint flanged die

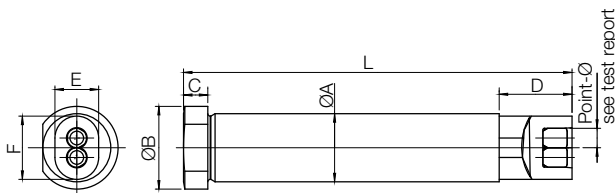

Type	L	Ø A ^{-0.005 -0.020}	Ø B	C	D	E	F	Point Ø
TOX 210.160	60	10	13	5	15	7	10	3
TOX 214.180	80	14	17	5	15	9	13	4
TOX 216.180	80	16	19	5	20	10	15	5
TOX 218.180	80	18	21	5	20	12	18	6
TOX 222.200	100	22	25	5	20	14	22	8
TOX 226.220	120	26	29	5	20	16	26	10

Dimensions in mm

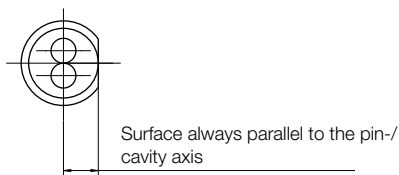

Anti-rotation device

TOX®-TWINpoint tools are secured against rotating by default. The surface on the flange which is in parallel to the pin-/cavity axis ensures the tool can not rotate inside the tool fixture. Suitable strippers can be found on page 8 and 9.

Dies

Dies, offset

The offset die is particularly useful where access to the piece part is difficult, e.g. C- and U-shaped sections, blanks with 90° offset, etc.

The tools can be used for single or multipoint applications. Special shapes are available on request.

The tools can be replaced quickly and easily.

TOX®-Round Joint Die, offset

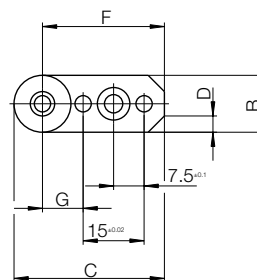
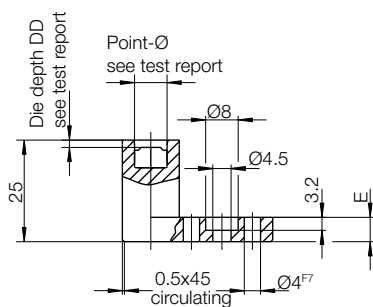

Type	B	C	D	E	F±0.02	G±0.02	Point Ø
TOX 50.25	10	35	3x45°	6	30	10	3 / 4 / 5 / (6)*
TOX 51.22	12	36	3x45°	6	30	10	6
TOX 51.25	14	37	4x45°	6	30	10	8
TOX 53.25	16	38	4.5x45°	10	30	10	10
TOX 54.25	20	45	4.5x45°	10	35	15	12

* only after consulting TOX® PRESSOTECHNIK

Dimensions in mm

TOX®-SKB Die, offset

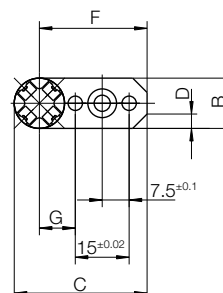
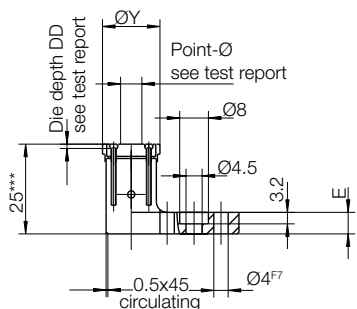

Type	B	C	D	E	F±0.02	G±0.02	Point Ø	Y**
SKB 50.25	10	35	3x45°	6	30	10	5 – 6	12
SKB 51.22	12	36	3x45°	6	30	10	6 – 7	14
SKB 51.25	14	37	4x45°	6	30	10	8 – 9	16
SKB 53.25*	16	38	4.5x45°	10	30	10	8 – 10	17.5

* joining with intermediate layer (e.g. glue/textiles)

** = with max. opened die

*** minimum dimension 16 mm, deliverable upon request

Dimensions in mm

Dies, flat

The flat die plate reaches into almost every corner of the piece part. The shape allows for smaller flanges and extremely compact design.

The tools can be used for single or multipoint applications. Special shapes are available on request.

The tools can be replaced quickly and easily.

TOX®-Round Joint Die, flat

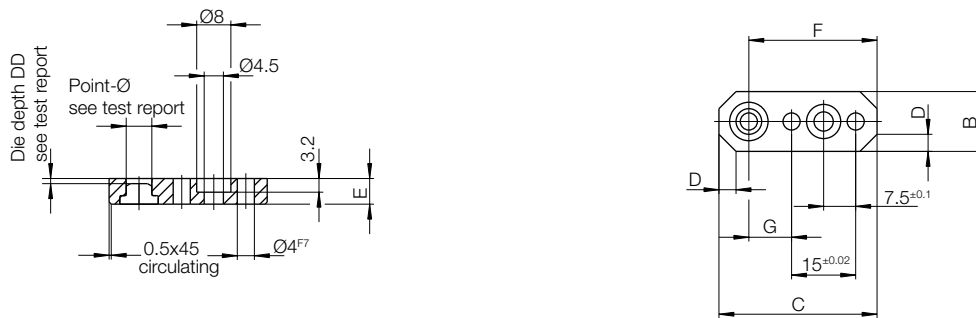

Type	B	C	D	E	F±0.02	G±0.02	Point Ø
TOX 40.25	10	35	3x45°	6	30	10	3 / 4 / 5 / (6)*
TOX 41.01	12	36	3x45°	6	30	10	6
TOX 41.25	14	37	4x45°	6	30	10	8
TOX 43.25	16	38	4.5x45°	10	30	10	10
TOX 44.25	20	45	4.5x45°	10	35	15	12

* only after consulting TOX® PRESSOTECHNIK

Dimensions in mm

Stripper

Punch Stripper, round

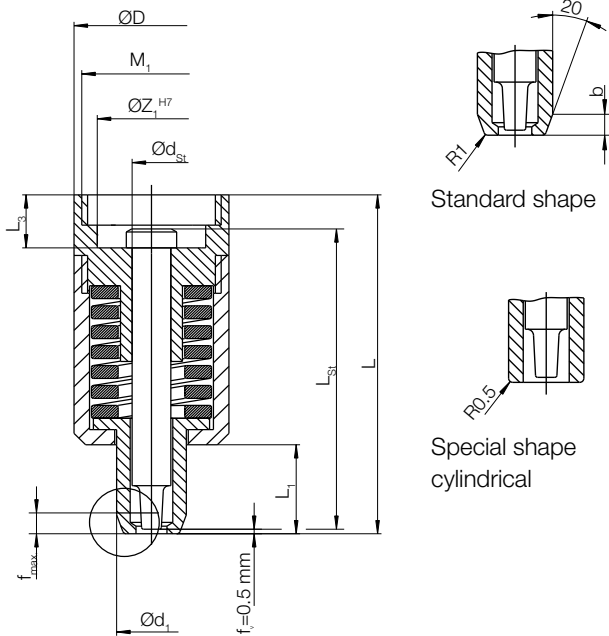

Punch stripper CSR for TOX®-Flanged Punches

For single and multipoint solutions, for holding flanges type CZP, CZE and CZW and for drives RZK, RZH, EPMR.

The punch stripper consist of punch holder, stripping sleeve, spring sleeve and special helical spring.

L_{St} = Length of punch

d_{St} = Diameter of punch

F_v = Preload force

f_v = Punch recessed

A description of how to calculate the punch stripper correctly can be found in data sheet 80.18 „Installation and design guidelines“.

Punch stripper suitable for holding flanges CZP, CZW, CZE

Type	L_{St}	d_{St}	$F_v(N)$	Rate of spring		$\varnothing D$	L	$\varnothing d_1$	b	$\varnothing Z_1^{H7}$	M_1	L_1	L_3	Spring type	Recommended die stripper
				R (N/mm)											
CSR 16.03.040	40	3	300	250		30	48	7	–	18	M20x1.5	13	10	SZ8590.016	
CSR 25.10.060	60	10	925	370		32	67.5	15	2.5	22	M24x1.5	11	12	CZF25	CMR 24...
CSR 25.10.080	80	10	925	370		32	87.5	15	2.5	22	M24x1.5	31	12	CZF25	CMR 24...
CSR 25.10.100	100	10	925	370		32	107.5	15	2.5	22	M24x1.5	51	12	CZF25	CMR 24...
CSR 32.10.080	80	10	970	485		40	88.5	18	5	28	M32x1.5	23.5	13	CZF32	CMR 24...
CSR 32.10.100	100	10	970	485		40	108.5	18	5	28	M32x1.5	43.5	13	CZF32	CMR 31...
CSR 38.10.080	80	10	2610	580		50	90.5	22	7	28	M42x1.5	12.5	15	CZF38	CMR 24.../31...
CSR 38.10.100	100	10	2610	580		50	110.5	22	7	28	M42x1.5	32.5	15	CZF38	CMR 32.../37...
CSR 51.10.100	100	10	4020	670		65	110.5	24	7	40	M56x1.5	19.5	15	CZF51	alle CMR

Dimensions in mm

Punch stripper suitable for drives RZK, RZH, EPMR

Type	L_{St}	d_{St}	$F_v(N)$	Rate of spring		$\varnothing D$	L	$\varnothing d_1$	b	$\varnothing Z_1^{H7}$	M_1	L_1	L_3	Spring type	Recommended die stripper
				R (N/mm)											
CSR 025.10.060	60	10	925	370		32	75.5	18	2.5	22	M24x1.5	11	20.05	CZF25	CMR 024
CSR 025.10.080	80	10	925	370		32	95.5	18	2.5	22	M24x1.5	31	20.05	CZF25	CMR 024
CSR 025.10.100	100	10	925	370		32	110.5	18	2.5	22	M24x1.5	51	20.05	CZF25	CMR 024...
CSR 032.10.080	80	10	970	485		40	95.5	18	5	22	M24x1.5	23.5	20.05	CZF32	CMR 024/030
CSR 032.10.100	100	10	970	485		40	115.5	18	5	22	M24x1.5	43.5	20.05	CZF32	CMR 024/030
CSR 032.10.120	120	10	970	485		40	135.5	18	5	22	M24x1.5	63.5	20.05	CZF32	CMR 024/030
CSR 038.10.080	80	10	2610	580		50	95.5	22	7	22	M24x1.5	12.5	20.05	CZF38	CMR 030/031
CSR 038.10.100	100	10	2610	580		50	115.5	22	7	22	M24x1.5	32.5	20.05	CZF38	CMR 030/031
CSR.038.10.120	120	10	2610	580		50	135.5	22	7	22	M24x1.5	52.5	20.05	CZF38	CMR 030/031
CSR 051.10.100	100	10	4020	670		65	115.5	24	7	22	M24x1.5	19.5	20.05	CZF51	alle CMR
CSR 051.10.120	120	10	4020	670		65	135.5	24	7	22	M24x1.5	39.5	20.05	CZF51	alle CMR

Dimensions in mm

Die Stripper, round

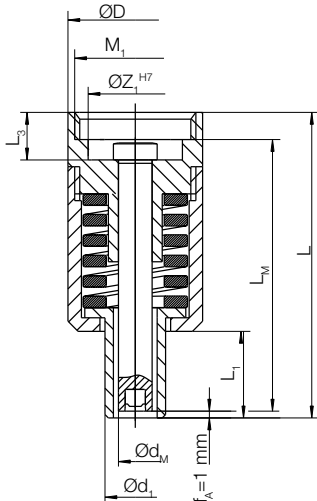

Die stripper CMR for TOX®-Flanged Dies

Die holder, for single and multipoint solutions, installed directly on plate with holding flanges type CZE and CZW and for mounting to TOX®-Powerpackage with holding flange type CZP. The die stripper consists of die holder, stripping sleeve, spring sleeve and special helical spring.

L_M = Length of die

d_M = Diameter of die

F_v = Preload force

F = Stripping force

f_A = Stripping travel

A description of how to calculate the die stripper correctly can be found in data sheet 80.18 „Installation and design guidelines“.

Die stripper suitable for holding flanges CZP, CZW, CZE

Type	L_M	d_M	F_v (N)	Rate of spring R (N/mm)	$\varnothing D$	L	$\varnothing d_1$	$\varnothing Z_1^{H7}$	M_1	L_1	L_3	Spring type
CMR 16.04.030	30	4	300	250	30	38	10	18	M20x1.5	3	10	SZ8590.016
CMR 24.14.060	60	14	900	95	32	68	19	22	M24x1.5	11.5	12	CZF24
CMR 24.14.080	80	14	900	95	32	88	19	22	M24x1.5	31.5	12	CZF24
CMR 24.14.100	100	14	900	95	32	108	19	22	M24x1.5	51.5	12	CZF24
CMR 25.10.060	60	10	2035	370	32	68	15	22	M24x1.5	11.5	12	CZF25
CMR 25.10.080	80	10	2035	370	32	88	15	22	M24x1.5	31.5	12	CZF25
CMR 25.10.100	100	10	2035	370	32	108	15	22	M24x1.5	51.5	12	CZF25
CMR 31.14.080	80	14	2275	350	40	89	18	28	M32x1.5	20	13	CZF31
CMR 31.14.100	100	14	2275	350	40	109	18	28	M32x1.5	40	13	CZF31
CMR 32.14.080	80	14	3150	485	40	89	18	28	M32x1.5	20	13	CZF32
CMR 32.14.100	100	14	3150	485	40	109	18	28	M32x1.5	40	13	CZF32
CMR 37.14.080	80	14	3410	325	50	91	22	28	M42x1.5	9	15	CZF37
CMR 37.14.100	100	14	3410	325	50	111	22	28	M42x1.5	29	15	CZF37
CMR 38.14.080	80	14	6090	580	50	91	22	28	M42x1.5	9	15	CZF38
CMR 38.14.100	100	14	6090	580	50	111	22	28	M42x1.5	29	15	CZF38

Dimensions in mm

Die stripper suitable for drives RZK, RZH, EPMR

Type	L_M	d_M	F_v (N)	Rate of spring R (N/mm)	$\varnothing D$	L	$\varnothing d_1$	$\varnothing Z_1^{H7}$	M_1	L_1	L_3	Spring type
CMR 024.14.060	60	14	900	95	32	76	19	22	M24x1.5	11.5	20.05	CZF24
CMR 024.14.080	80	14	900	95	32	96	19	22	M24x1.5	31.5	20.05	CZF24
CMR 025.10.060	60	10	2035	370	32	76	15	22	M24x1.5	11.5	20.05	CZF25
CMR 025.10.080	80	10	2035	370	32	96	15	22	M24x1.5	31.5	20.05	CZF25
CMR 031.14.080	80	14	2258	350	40	96	18	28	M24x1.5	24	20.05	CZF31
CMR 031.14.100	100	14	2258	350	40	116	18	28	M24x1.5	44	20.05	CZF31
CMR 032.14.080	80	14	3150	485	40	96	18	28	M24x1.5	24	20.05	CZF32
CMR 032.14.100	100	14	3150	485	40	116	18	28	M24x1.5	44	20.05	CZF32
CMR 037.14.080	80	14	3735	325	50	96	22	28	M24x1.5	13	20.05	CZF37
CMR 037.14.100	100	14	3735	325	50	116	22	28	M24x1.5	33	20.05	CZF37
CMR 038.14.080	80	14	6670	580	50	96	22	28	M24x1.5	13	20.05	CZF38
CMR 038.14.100	100	14	6670	580	50	116	22	28	M24x1.5	33	20.05	CZF38

Dimensions in mm

Stripper

Punch Stripper TWINpoint

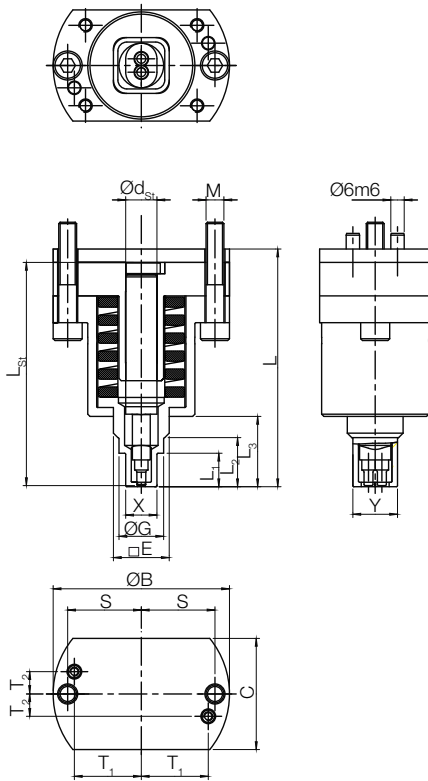

Punch stripper CSRT for TOX®-TWINPoint Punch

For single and multipoint solutions, installed directly on plate.

The punch stripper consists of punch holder, stripping sleeve, spring sleeve and special helical spring.

L_{st} = Length of punch

d_{st} = Diameter of punch

F_v = Preload force

f_v = Punch recessed

A description of how to calculate the punch stripper correctly can be found in data sheet 80.18 „Installation and design guidelines“.

Type	L_{st}	d_{st}	F_v (N)	Rate of spring		$\emptyset B$	C	L	M	X	Y	E	$\emptyset G$	L_1	L_2	L_3	T_1	T_2	S	Point \emptyset	Spring type
				R (N/mm)	R (N/mm)																
CSRT 32.10.04.080.035.00	80	10	970	485	485	71	42	86.5	M8	10	14	21	18	20.5	29	9	29	4	4	CZF32	
CSRT 32.10.04.100.035.00	100	10	970	485	485	71	42	107	M8	10	14	21	15	18	30	40.5	29	9	29	4	CZF32
CSRT 32.10.04.120.035.00	120	10	970	485	485	71	42	127	M8	10	14	21	15	18	50	60.5	29	9	29	4	CZF32
CSRT 38.14.06.080.065.00	80	14	2610	580	580	79	50	86.5	M8	14	20	25	-	8	-	10.5	30	10	33	6(5)	CZF38
CSRT 38.14.06.100.065.00	100	14	2610	580	580	79	50	107	M8	14	20	25	-	14	-	30.5	30	10	33	6(5)	CZF38
CSRT 38.14.06.120.065.00	120	14	2610	580	580	79	50	127	M8	14	20	25	-	14	-	50.5	30	10	33	6(5)	CZF38
CSRT 51.18.08.100.075.00	100	18	4020	670	670	89	60	107	M8	15	23	30	-	9	-	19.5	35	10	38	8	CZF51
CSRT 51.18.08.120.075.00	120	18	4020	670	670	89	60	127	M8	15	23	30	-	19	-	39.5	35	10	38	8	CZF51
CSRT 51.10.10.100.100.00	100	2x10	4020	670	670	89	60	107	M8	18	18	30	-	11	-	19.5	35	10	38	10	CZF51
CSRT 51.10.10.120.100.00	120	2x10	4020	670	670	89	60	127	M8	18	28	30	-	31	-	39.5	35	10	38	10	CZF51

Dimensions in mm

Die Stripper TWINpoint

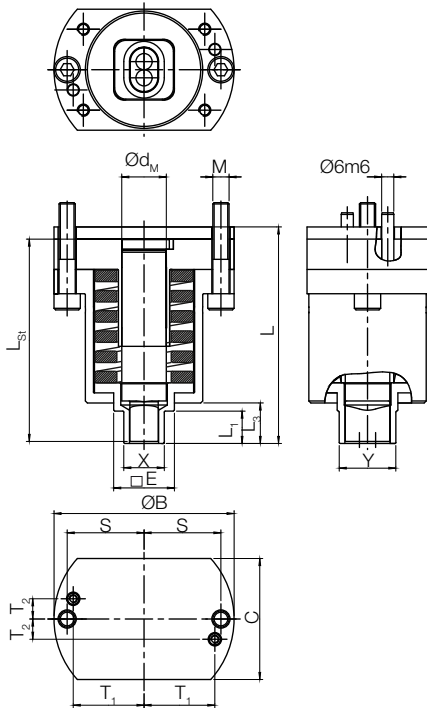

Die stripper CMRT for TOX®-TWINpoint Flanged Dies

Die stripper, for single and multi-point solutions, with die holder installed directly on plate.

The die stripper consists of die holder, stripping sleeve, spring sleeve and special helical spring.

L_M = Length of die

d_M = Diameter of die

F_V = Preload force

f_V = Die recessed

A description of how to calculate the die stripper correctly can be found in data sheet 80.18 „Installation and design guidelines“.

Type	L_M	d_M	Rate of spring		$\varnothing B$	C	L	M	X	Y	E	L_1	L_3	T_1	T_2	S	Point \varnothing	Spring type	
			F_V (N)	R (N/mm)															
CMRT 30.14.04.080.00	80	14	680	170	71	42	87	M8	14	18	21	12	21	29	9	29		4	CZF30
CMRT 37.18.06.080.00	80	18	1788	325	79	50	87	M8	18	24	25	10	11	30	10	33	6 (5)	CZF37	
CMRT 50.22.08.100.00	100	22	2310	385	89	60	107	M8	20	28	30	16	20	30	10	38		8	CZF50
CMRT 62.26.10.120.00	120	26	3150	630	102	73	127	M8	22	32	34	15	27	35	15	44.5		10	CZF62

Dimensions in mm

Holding Flanges

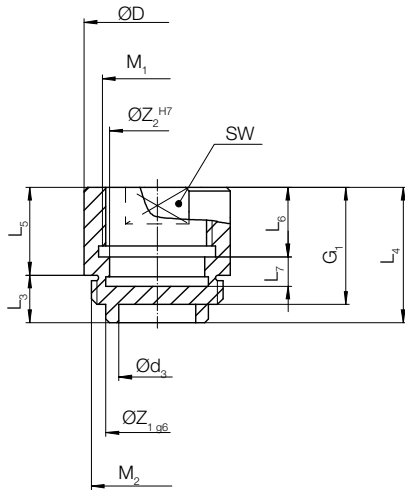

Holding flange CZP

Holding flange for stripper type CSR and CMR, for screwing onto the TOX®-Powerpackage working piston.

Type	ØD _{-0.2}	L ₃	L ₄	L ₅	L ₆	L ₇	M ₁	M ₂	Z _{1 g6}	ØZ _{2 H7}	Ød ₃	G ₁	SW
CZP 022.024.026.000	31.8	12	38	26	14	7	M22x2	M24x1.5	22	18	18	33	27
CZP 030.024.032.001	39.8	12	44	32	19	8	M30x2	M24x1.5	22	26	18	39	36
CZP 022.032.023.000	39.8	13	36	23	14	7	M22x2	M32x1.5	28	18	21	31	36
CZP 030.032.032.000	39.8	13	45	32	19	8	M30x2	M32x1.5	28	26	21	40	36
CZP 030.042.027.000	49.8	15	42	27	19	8	M30x2	M42x1.5	28	26	21	37	46
CZP 030.056.029.000	64.8	15	44	29	19	8	M30x2	M56x1.5	40	26	25	39	60

Dimensions in mm

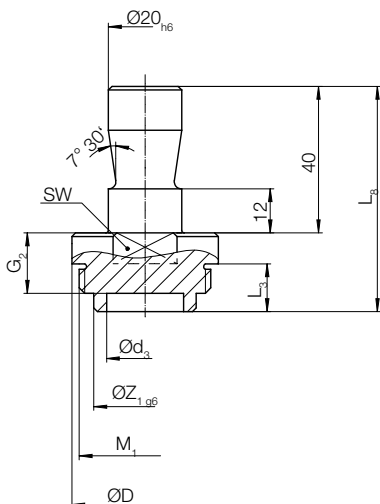

Holding flange CZW

Holding flange for stripper type CSR and CMR, adaptable on plate side.

Type	L ₃	L ₈	ØD _{-0.2}	M ₁	Z _{1 g6}	Ød ₃	G ₂	SW
CZW 020.024.008.000	12	60.5	31.8	M24x1.5	22	18	15.5	27
CZW 020.032.008.000	13	61.5	39.8	M32x1.5	28	21	16.5	36
CZW 020.042.008.000	15	63.5	49.8	M42x1.5	28	21	18.5	46
CZW 020.056.009.000	15	64.5	64.8	M56x1.5	40	25	19.5	60
CZW 020.024.009.000	19	67.5	32	M24x1.5	22	17.3	23.5	30

Dimensions in mm

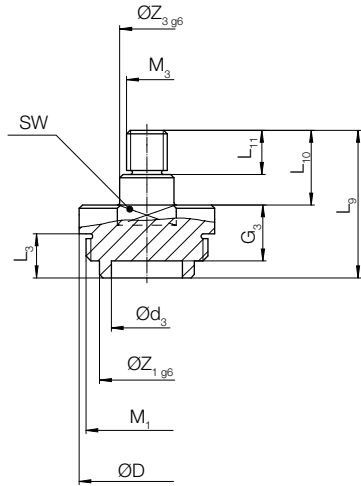

Holding flange CZE

Holding flange for stripper type CSR and CMR, for screwing into plate.

Type	ØD _{-0.2}	L ₃	L ₉	L ₁₀	L ₁₁	M ₁	M ₃	Z _{1g6}	ØZ _{3g6}	Ød ₃	G ₃	SW
CZE 012.024.009.000	31.8	12	43.0	22	13	M24x1.5	M12x1.5	22	16	18	16.0	27
CZE 012.032.008.000	39.8	13	43.5	22	13	M32x1.5	M12x1.5	28	16	21	16.5	36
CZE 012.042.008.000	49.8	15	45.5	22	13	M42x1.5	M12x1.5	28	16	21	18.5	46
CZE 020.056.009.000	64.8	15	49.5	22	15	M56x1.5	M20x1.5	40	24	25	19.5	60
CZE 012.024.012.001	39.8	19	53.0	22	13	M24x1.5	M12x1.5	22	16	17.5	27.0	36

Dimensions in mm

Special Helical Springs

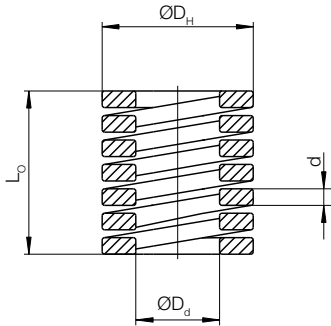

Special helical spring CZF

Special helical spring suitable for stripper type CSR and type CMR, ground to parallel and angular requirements.

$\varnothing D_H$ = Sleeve diameter (+ 0.2 mm tolerance)

$\varnothing D_d$ = Mandrel diameter (- 0.2 mm tolerance)

L_0 = Free length

d = Wire diameter

S_n = Spring travel

F = Force

R = Rate of spring ($\pm 10\%$ tolerance)

Type	$\varnothing D_H$	$\varnothing D_d$	L_0	d	Rate of spring R (N/mm)	Long lifetime 60 % S_n		Average lifetime 80 % S_n		Max. travel/force $S_n F_{max}$		Color
						(mm)	F (N)	(mm)	F (N)	(mm)	(N)	
CZF 24	25	15.2	33	4.1	93	6.3	586	8.4	781	10.5	977	-
CZF 22	25	12.5	31	3.1	110	6.7	737	9.0	990	11.2	1232	blue
CZF 23	25	12.5	31	4.1	275	5.8	1595	7.7	2118	9.6	2640	red
CZF 25	25	12.5	31	4.6	370	4.8	1776	6.4	2368	8.0	2960	yellow
CZF 30	32	16	37	4.0	170	8.0	1360	10.6	1802	13.3	2261	blue
CZF 31	32	16	37	5.3	350	6.8	2380	9.1	3185	11.4	3990	red
CZF 32	32	16	37	5.6	485	5.7	2765	7.6	3686	9.5	4608	yellow
CZF 36	40	20	49.5	4.8	170	10.7	1819	14.3	2434	17.9	3043	blue
CZF 37	40	20	49.5	6.2	325	9.2	2990	12.2	3965	15.3	4973	red
CZF 38	40	20	49.5	7.3	580	7.7	4466	10.2	5916	12.8	7424	yellow
CZF 49	50	25	62	6.0	195	13.4	2613	17.9	3491	22.4	4370	blue
CZF 50	50	25	62	7.4	385	11.5	4428	15.4	5929	19.2	7392	red
CZF 51	50	25	62	9.1	670	9.6	6432	12.8	8576	16.0	10720	yellow
CZF 62	63	38	74	11	630	13.7	8618	18.2	11491	22.8	14364	red

Dimensions in mm

Note:

To avoid any side forces on the TOX®-Tool, no standard die springs must be used.

Assembly tools

Open end wrench CZG

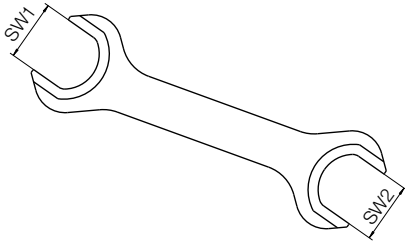

Special tool for changing TOX®-Tools, TOX®-Helical Springs and holding flanges.

Type	SW 1	SW 2	appropriate for
CZG 27-30.00	27	30	CZP/CZW/CZE 25 CSR/CMR 25/CMR 24
CZG 36-38.00	36	38	CZP/CZW/CZE 32 CSR/CMR 32/CMR 31
CZG 46-60.00	46	60	CSR/CMR/CZP/CZW/CZE 38/CMR 37 CSR/CMR/CZP/CZW/CZE 51

Special hexagon socket CZN

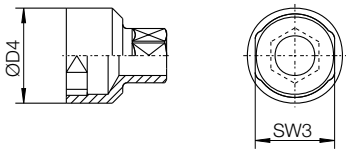

Type	SW 3	Ø D4	appropriate for
CZN 25	30	36.5	CSR/CMR 25, CMR 24
CZN 32	38	45.5	CSR/CMR 32, CMR 31
CZN 38	46	55.5	CSR/CMR 38, CMR 37
CZN 51	60	69.5	CSR 51